

GEMStar XT ARR-EV-A10-P-EPP Enhanced Dry Pump Package



Our Enhanced dry Pump Package combines our separate products into a single offering that will minimize your maintenance costs at a great value

Engineered for GEMStar XT and XT-P for optimum process performance, reliability and low pump maintenance cost

The best dry pump

EBARA EV-A10

For more details see [ARR-EV-A10](#)

The best particle/contamination trap for pump protection

Our Multi-Trap Provides both stainless steel gauze and activated charcoal filters

Easy filter replacement

Digital vacuum gauge for pump vacuum performance monitoring

For more details see [ARR-RD003000-datasheet.pdf](#)

A spare Multi-trap filter set for your next required service

Recommend annual filter replacement

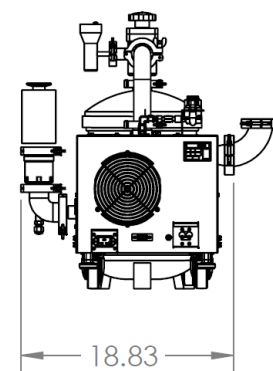
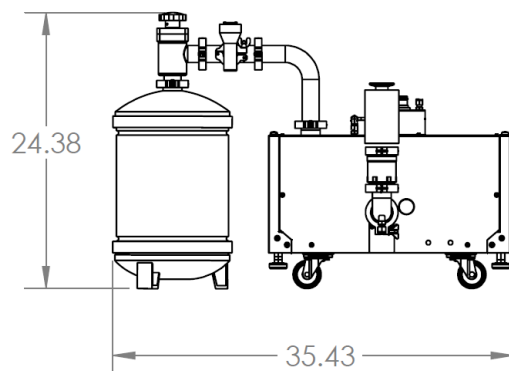

Molecular Innovation™